

Modular Cooking Range Line EVO900 4-Hot Plates Electric Boiling Top

ITEM # _____

MODEL # _____

NAME # _____

SIS # _____

AIA # _____



392040 (Z9ECEH4Q00)

4-hot square plates (4 kW each) electric boiling top - 400V

Short Form Specification

Item No. _____

To be installed on open base installations, bridging supports or cantilever systems. Four 4 kW square cast-iron hot plates hermetically sealed to the one-piece top. Exterior panels of unit in stainless steel with Scotch Brite finish. Extra strength work top in heavy duty 2 mm stainless steel. Right-angled side edges to allow flush-fitting junction between units.

Main Features

- Unit to be mounted on open base cupboards, bridging supports or cantilever systems.
- The four 4kW cast-iron plates are hermetically sealed to the one-piece top. Hot plates with a power of 4kW for each plate.
- The special design of the control knob system guarantees against water infiltration.
- IPX5 water protection.
- Top configuration allows installation on ambient base only (not possible to install on refrigerated nor freezer base).
- Suitable for countertop installation.

Construction

- All exterior panels in Stainless Steel with Scotch Brite finishing.
- AISI 304 stainless steel worktop, 2mm thick.
- Model has right-angled side edges to allow flush fitting joints between units, eliminating gaps and possible dirt traps.
- Unit is 900mm deep to give a larger working surface area.

APPROVAL: _____

Optional Accessories

- 2 cast iron plate bars for electric cooking top PNC 206056
- Junction sealing kit PNC 206086
- 4 wheels, 2 swivelling with brake (EVO700/900). It is mandatory to install with base supports for feet/wheels. PNC 206135
- Support for bridge type installation, 800 mm PNC 206137
- Support for bridge type installation, 1000 mm PNC 206138
- Support for bridge type installation, 1200 mm PNC 206139
- Support for bridge type installation, 1400 mm PNC 206140
- Support for bridge type installation, 1600 mm PNC 206141
- Side handrail for right/left hand PNC 206165
- Frontal handrail 800 mm PNC 206167
- Large handrail (portioning shelf) 800 mm PNC 206186
- Frontal handrail 1200 mm PNC 206191
- Frontal handrail 1600 mm PNC 206192
- Water column with swivel arm (water column extension not included) PNC 206289
- Water column extension PNC 206290
- Chimney upstand, 800 mm PNC 206304
- 2 side covering panels, height 250 mm, depth 900 mm PNC 206321
- Chimney grid net, 400mm PNC 206400

Front

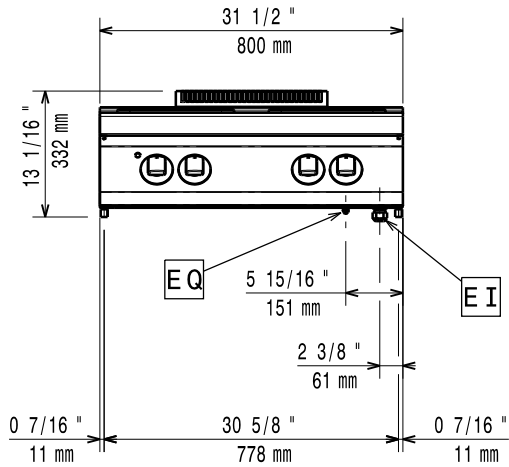

Side

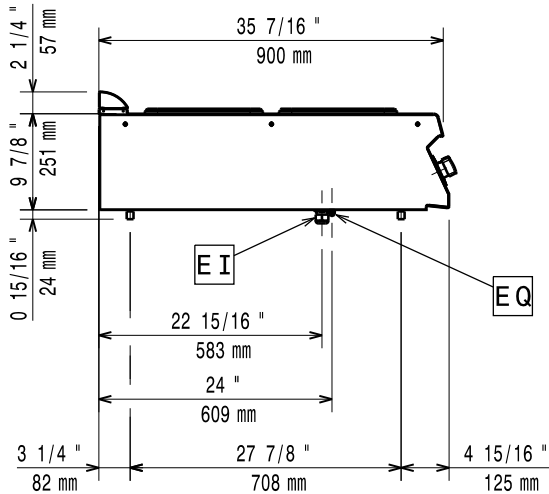

EI = Electrical inlet (power)

EQ = Equipotential screw

Top

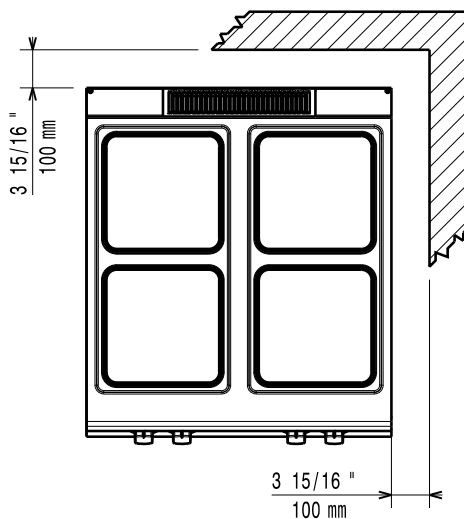

Electric

Supply voltage: 380-400 V/3N ph/50-60 Hz
Predisposed for:
Total Watts: 16 kW

Gas

Natural gas - Pressure: 7" w.c. (17.4 mbar)
LPG Gas Pressure: 11" w.c. (27.7 mbar)

Key Information:

If appliance is set up or next to or against temperature sensitive furniture or similar, a safety gap of approximately 150 mm should be maintained or some form of heat insulation fitted.

Net weight: 60 kg
Shipping weight: 70 kg
Shipping height: 530 mm
Shipping width: 1010 mm
Shipping depth: 860 mm
Shipping volume: 0.46 m³
Certification group: EH94T
Front Plates Power: 4 - 4 kW
Back Plates Power: 4 - 4 kW
Front Plates dimensions: 300x300 300x300
Back Plates dimensions: 300x300 300x300